

AERODYNE MODEL 54 A.C. SUPERHET



CIRCUIT.—An inductively-coupled transformer links the aerial to V1, an H.F. pentode. The cathode lead of this includes a potentiometer for controlling the sensitivity of the set.

Coupling to the frequency-changer V2 is through an H.F. transformer.

Signals are then fed through an I.F. transformer, tuned to 465 kc., to V3, an H.F. pentode, and through a second I.F. transformer to V4, a double diode triode.

One diode of V4 is used for demodulation and the other to supply A.V.C. bias to the grids of the preceding valves.

Volume is controlled by R12, which varies the input to the grid of V4.

The L.F. output of V4 is passed by a resistance and capacity stage to the output pentode V5 and then after amplification to the moving-coil speaker.

Bias is applied to the grid of V5, the

this set in place of the more customary separate screened coils. It will be found that this construction makes for greater accessibility and ease in fault finding.

The large condenser, C20A, in parallel with C20, decouples the oscillator anode circuit. It may not be found in some models of the receiver.

In some models also it may be found that modifications have been made in the biasing network associated with the output pentode. These changes, however, should not present any special difficulties.

Removing Chassis.—First remove five knobs from the front of the cabinet—they are fixed by spring clips—free the speaker leads from the cleat, and then remove four bolts from underneath the cabinet.

By tilting the back of the chassis so that the dial assembly clears the bottom of the

When the chassis is disconnected from the speaker, the mains should not on any account be switched on. The speaker field forms the smoothing choke and the connection of the supply would endanger the mains transformer, rectifier and smoothing condensers.

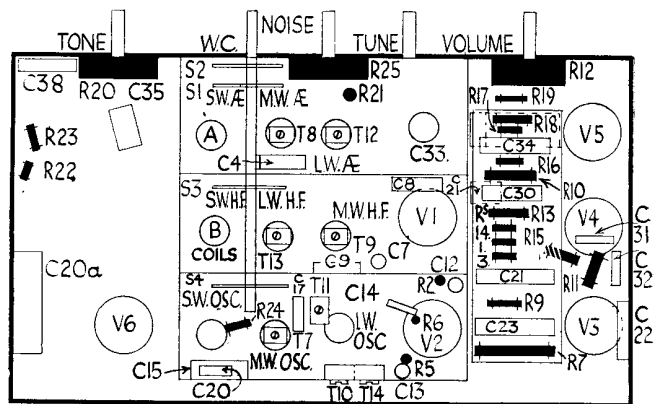
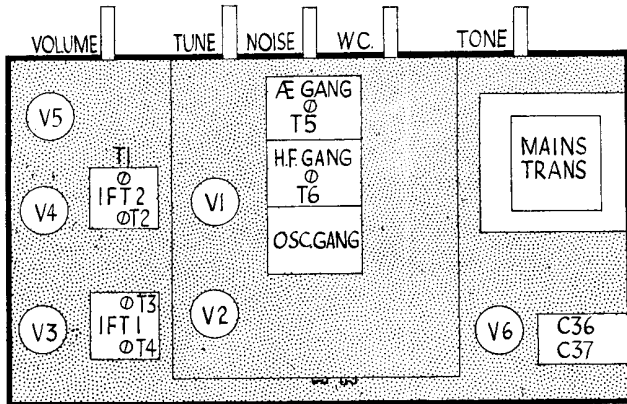

These diagrams of the top (left) and underside (right) of the Aerodyne chassis enable all components and trimmers to be located. An interesting feature is the special central assembly of unscreened coils.

cathode being taken to earth. This bias is obtained from a potentiometer arrangement connected across the speaker field, which is in the negative H.T. line.

Tone is controlled by C28 and a variable resistance R20.

Mains equipment consists of transformer, full wave rectifier, electrolytic condensers and the speaker field.

Special Notes.—The three dial lights are each rated at 3.5 volts .3 amp. They are enclosed in a box which rotates with the gang condenser. To remove them, hold the box firmly against the scale with one hand and withdraw the dial light holder with the other hand.

Provision is made for the connection of a pick-up. The connection is made in a rather unusual manner—between the grid of V4 and chassis. The pick-up input is not, therefore, controlled by the volume control, and it is necessary to use an external potentiometer of suitable value to match the particular pick-up employed.

Attention is drawn to the special channel-shape coil unit which is used in

speaker baffle, the chassis may be withdrawn to the extent of the speaker leads. This will be far enough for the usual inspection and test.

Should it be necessary to completely free the chassis, the speaker leads must be unsoldered from the speaker. Reconnection is as follows, reading from the top of the terminal strip: (1) Red lead, (2) blue, (3) blue, and (4) black.

VALVE READINGS

No signal. Volume maximum. 200-volt A.C. mains.

V.	Type.	Electrode.	Volts.	M. a.
1	(All Mullard except rectifier.) VP4B met. (7)	Anode ..	240	2.6
		Screen ..	240	1.1
2	TH4 met. (7) ..	Anode ..	240	1
		Screen ..	50	1.5
3	VP4B met. (7)	Osc. anode ..	90	5.4
		Anode ..	240	9.5
4	TDD4 met. (7)	Screen ..	175	3.5
		Anode ..	130	3.8
5	Pen.4VA (7) ..	Anode ..	220	26.9
		Screen ..	240	2.2
6	R2 (4) (Brimar)	Filament	240	—

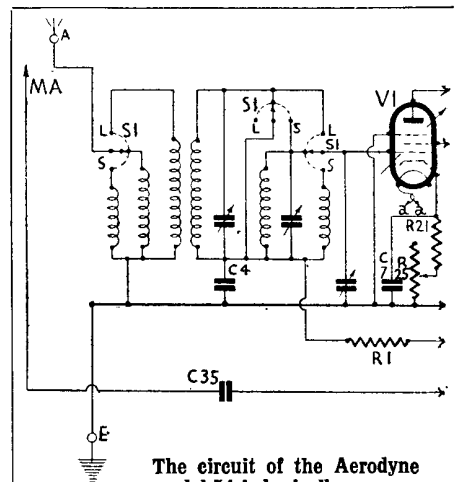

The circuit of the Aerodyne model 54 is basically conventional and incorporates five valves plus a rectifier.

Circuit Alignment Notes

I.F. Circuit.—Connect a modulated oscillator to the grid cap of V2 and an output meter across the external speaker terminals. The meter range should have a maximum reading of about 1 volt and the strength of the signal injected should be enough to give a deflection of about .5 volt.

Tune the oscillator to 465 kc. and adjust T1, T2, T3 and T4 for maximum.

Short Waves.—Connect the oscillator, tuned to 17 or 18 metres, to the aerial and earth terminals and tune the receiver to whichever wavelength is used.

Adjust T5 and T6 for maximum output.

Tune the set and oscillator to 31 metres and check. If the calibration is correct but the output is low, adjust the loose turns on the aerial and H.F. coil (A and B on chassis diagram) for maximum output.

Tune to 50 metres, at which point the calibration and alignment should be correct.

Medium Waves.—Set the pointer to the

250 metre index mark and inject a 250 metre signal to the aerial and earth terminals.

Adjust T7 for maximum output, then trim T8 and T9.

Tune the oscillator and receiver to 500 metres and, while rocking the gang condenser, adjust T10 for maximum.

Long Waves.—Tune the receiver to 1,300 metres and adjust T11 and then T12 and T13 for maximum output.

Tune to 1,900 metres and adjust T14 for maximum.

Return to 1,300 metres and check the adjustment of T12 and T13.

WHEN referring to "Service Engineer," readers are recommended first to read the Test Report panel. This is intended to supply in briefest possible form general and technical descriptive matter, including such points as the required impedance of extra speakers.

The service review proper supplements this information and provides the data required while a repair is actually being undertaken.

RESISTANCES

R.	Purpose.	Ohms.
1	V1 A.V.C. decoupling ..	100,000
2	V2 screen decoupling potr. ..	20,000
3	V2 A.V.C. decoupling ..	100,000
4	V2 screen decoupling potr. ..	20,000
5	V2 cathode bias ..	340
6	V2 osc. grid leak ..	30,000
7	V2 osc. anode decoupling ..	10,000
8	V3 cathode bias ..	100
9	V3 screen decoupling ..	10,000
10	H.F. filter ..	50,000
11	V3 A.V.C. decoupling ..	1 meg.
12	Volume control and demod. diode load (part) ..	.5 meg.
13	V4 grid leak ..	1 meg.
14	V4 cathode bias ..	500
15	A.V.C. diode load ..	1 meg.
16	V4 anode decoupling ..	20,000
17	V5 grid stopper ..	100,000
18	V5 grid leak ..	.5 meg.
19	V5 grid bias decoupling ..	100,000
20	Tone control ..	50,000
21	V1 cathode bias ..	300
22	V5 grid bias potr. ..	60,000
23	V5 grid bias potr. ..	250,000
24	Osc. reaction stabiliser (s.w.) ..	100
25	Sensitivity control ..	3,000
L17	Speaker field ..	1,500

CONDENSERS

C.	Purpose.	Mfds.
4	V1 A.V.C. decoupling ..	.02
7	V1 cathode bias shunt ..	.1
8	V1 anode decoupling ..	.1
9	V2 A.V.C. decoupling ..	.02
12	V2 screen decoupling ..	.1
13	V2 cathode bias shunt ..	.1
14	V2 osc. grid ..	.0001
15	Oscillator padding (s.w.) ..	.008
20	V2 osc. anode decoupling ..	.1
20a	V2 osc. anode decoupling ..	.4
21	V3 A.V.C. decoupling ..	.05
22	V3 cathode bias shunt ..	.1
23	V3 screen decoupling ..	.1
24	H.F. filter ..	.0001
25	H.F. filter ..	.0001
30	L.F. coupling ..	.01
31	A.V.C. diode coupling ..	.0003
32	H.F. filter ..	.0005
33	V4 cathode bias shunt ..	.25
34	L.F. coupling ..	.02
35	Mains aerial ..	.0002
36	H.T. smoothing ..	x
37	H.T. smoothing ..	x
38	Tone control ..	.02
39	V5 grid decoupling ..	1

Aerodyne 54 on Test

MODEL 54.—Standard model for 200-250 volt, 50-100 cycle A.C. mains; 13 gns.

DESCRIPTION.—A three-waveband, five-valve, plus rectifier, A.C. superhet table receiver. Modern design, well-built walnut cabinet.

FEATURES.—Eight tuned circuits. Dual-ratio drive with illuminated "spearhead" indicator. Delayed A.V.C. Pick-up and extra speaker sockets. Extra speaker should have impedance of about 2 ohms.

LOADING.—70 watts.

Sensitivity and Selectivity

SHORT WAVES (16-50 metres).—Well up to average. There is no drift and calibration is reasonably accurate.

MEDIUM WAVES (200-555 metres).—Capable of giving reception of practically any station working with a reasonable aerial. Spread appreciable only on local stations. Background quiet; whistles not very noticeable.

LONG WAVES (800-2,000 metres).—Sensitivity well maintained; selectivity up to standard. Good programme strength from all usual transmissions with a moderate aerial.

Acoustic Output

Crisp and clean; there is appreciable attack and upper partials radiate very well. Balance nicely maintained; speech very natural.

QUICK TESTS

Quick tests are available on this receiver on the terminal strip at the back of the speaker transformer. Volts measured between this and the chassis should be:—

- (1) Top, 100 volts, chassis positive.
- (2) 220 volts.
- (5) 240 volts.
- (3), (4) and (6) are blank.

