

BELMONT 555

Four-valve, plus rectifier, three wave-band superhet suitable for 200-250v. A.C. supplies. An American-type set marketed about 1935 by British Belmont, Ltd. Present service stockists: Shannons & Bishop, Ltd., 182, Wardour Street, London, W.1, and Price & Co. (Manchester), Ltd., 78, Tib Street, Manchester, 4.

Circuit.—Three bands are covered and on short and medium the aerial input is direct to the V1 grid coils through a small capacity. On L.W. a transformer is brought into circuit. There is a fixed tuned I.F. filter.

V1 is the frequency changer with tuned grid oscillator circuits. There are anode reaction windings and the common reactance of the padding condensers is also utilised.

Straightforward trimmer-tuned I.F. transformers link up V2, the I.F. amplifier, and V3, a double-diode screen-grid valve.

The diodes are strapped and the diode load, R7, is also the volume control. A pick-up connection is introduced at this point. A.V.C. is taken off by R5.

The demodulated carrier voltage is also used to bias the grid of the L.F. (screen-grid) section of V3. R9 is the anode load, C14, the L.F. coupler and R10 the grid leak of V4, the output pentode.

For V4 bias R10 is returned to R11, R12, a potentiometer across the speaker field which is in the negative lead, so making the chassis (and cathodes) positive.

H.T. is derived from a full-wave rectifier in the conventional transformer circuit.

GANGING

I.F. Circuits.—Tune to bottom M.W. band, volume at maximum, inject 465 kc. via .1 mfd. to signal grid of V1 and adjust four I.F. trimmers.

Keep input low to prevent A.V.C. working.

S.W. Band.—Tune to 16.7 m. Inject 16.7 m. and adjust T1 and T2 for maximum.

Tune to 50 m., inject 50 m. and check results, compromising with T1 and T2 if necessary. Do not bend the gang condenser vanes.

Make sure during S.W. adjustments that the fundamental signal is tuned in and not the image which appears at a higher wavelength.

M.W. Band.—With gang out of mesh, inject 187.5 m. and adjust T3 for maximum.

Inject 214.3 m., tune in signal and adjust T4 for maximum.

Tune to 500 m., inject 500 m., and pad with T5 while rocking gang slightly.

L.W. Band.—With gang at minimum, inject 923 m., and adjust T6 and T7 for maximum.

Tune to 2,000 m., inject 2,000 m., and pad with T8 while rocking gang.

The chassis is compact and the trimmers are conveniently grouped. The padders are accessible from above.

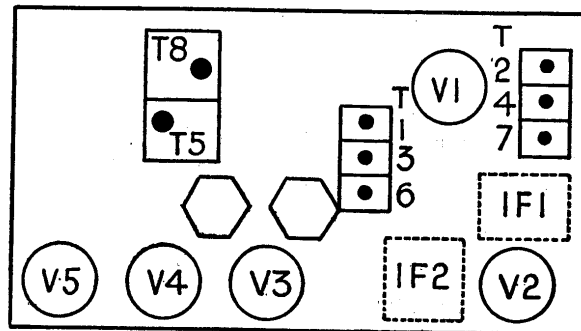

VALVE READINGS

V	Type	Electrode	Volts
1	6A7	Anode Screen Cathode	200 100 3
2	6D6	Anode Screen Cathode	200 100 3
3	6B7	(Circuit resistances too high)	
4	42E	Anode Screen	190 200
5	80	Rectifier	—

Pilot lamp, 6-8 v.

RESISTANCES

R	Ohms	R	Ohms
1	250	7	1 meg.
2	50,000	8	1 meg.
3	15,000	9	.25 meg.
4	350	10	.5 meg.
5	.5 meg.	11	.8 meg.
6	19,000	12	.201 meg.

CONDENSERS

C	Mfds.	C	Mfds.
1	20 mmfds.	11	.1 200 v.
2	35 mmfds.	12	250 mmfds.
3	.1 200 v.	13	250 mmfds.
4	100 mmfds.	14	.02 400 v.
5	2,000 mmfds.	15	.025
6	155 mmfds.	16	.1 200 v.
7	275 mmfds.	17	8 350 v.
8	3,800 mmfds.	18	8 300 v.
9	.1 200 v.	19	.1 200 v.
10	.01 200 v.		

WINDINGS

L	Ohms	L	Ohms
1	.01	8	9
2	4	9	10
3	70	10	13
4	13	11	21
5	.01	12	9
6	1	13	9
7	7	Field	1,500

Vibrator Makeshift

IN a recent case, the moving element of a vibrator was faulty, so that, although it was interrupting the D.C. supply and setting up an A.C. voltage across the transformer, it was not rectifying correctly. By taking the output into an ordinary rectifier valve suitably connected the unit was made workable.

Aerial Lead-in Fault

WHEN making a service call, it was found that on the long-wave band of a superhet the results were very poor. The fault was discovered by using a 5-watt neon which I carry on outside jobs, and which is protected by a metal valve screen, such as that used in American midgets.

One prong of the neon was inserted in the unearthed side of the A.C. supply, and the earth wire connected to the free prong. The neon showed a full glow, as it should do. Next the aerial was applied. There should not have been a glow, but the neon showed about a quarter glow.

It was found that twin flex had been used for part of the aerial and earth lead-in. On running separate leads, the volume on the long waves was increased about 50 per cent.

In view of the shortage of test equipment due to the war, the neon makes a good substitute for some of the more accurate test apparatus. Resistances of values up to about 10 megohms can be measured, and with a D.C. supply, condensers may be tested by forming a flashing circuit in conjunction with resistances. A small amount of experimenting will soon bring to light many other uses.—ALFRED ROSE.

A MARCONI 262 was being tested for hum. Both the 4 and 8 mfd. main smoothing condensers were worn out. They were replaced, but the hum, although much reduced, was still there on very weak volume.

The other condensers were tried by paralleling substitutes, and it was found that a 2 mfd. condenser connected between soldering tags Nos. 8 and 13 was open circuited internally. This is across the H.T. to some of the H.F. valves and replacement effected a complete cure.

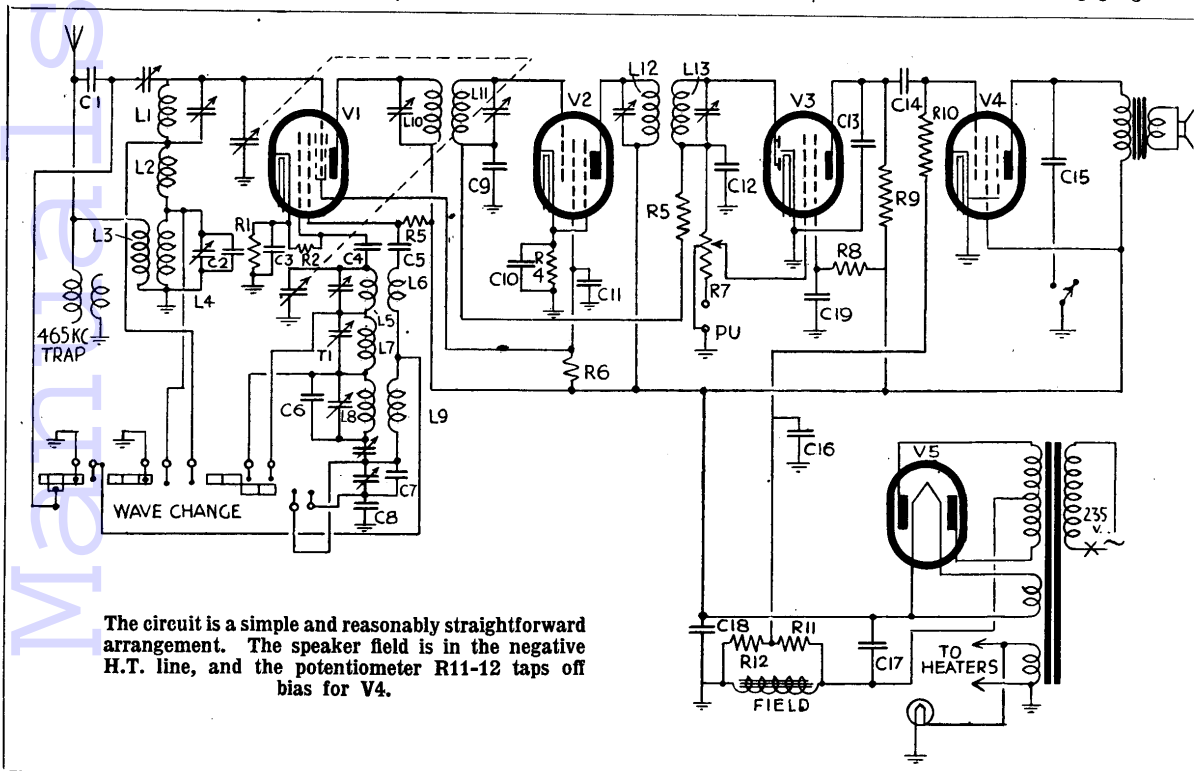

The circuit is a simple and reasonably straightforward arrangement. The speaker field is in the negative H.T. line, and the potentiometer R11-12 taps off bias for V4.