

DECCA 99 FOUR-BAND SIX

CIRCUIT.—The aerial is coupled to the grid of V1, an H.F. pentode operating as an H.F. amplifier, via a set of tuned aerial coils. V1 is tuned anode coupled to V2, a triode-hexode frequency changer, that converts the incoming signal to a frequency of 456 kcs.

The converted signal then passes via an I.F. transformer to V3, another H.F. pentode and the I.F. amplifying stage of the receiver. A further I.F. transformer couples V3 to the demodulating diode of V4, a double diode valve. The other diode of V4, fed by a coupling condenser, provides a D.C. potential that is utilised by being fed back to give automatic volume control.

The coupling arrangements to the grid of V5, an output pentode, include a manual volume control. In the anode circuit of V5 is connected the speaker matching transformer and also a variable resistance and condenser in series to provide tone control. A pentode compensator condenser is connected between the anode of the valve and cathode.

Mains equipment consists of a mains transformer, a full wave rectifying valve, V6, electrolytic smoothing condensers and smoothing choke (speaker field energising coil).

Chassis Removal.—The cabinet has a false bottom that permits inspection of the underside of the chassis.

Remove the back of the cabinet (sliding clips) and the three control knobs from the front. These are of the grub screw fixing type. Of the combined tuning and volume control, the smaller knob is of the grub screw fixing type and removal of this enables the larger knob to be pulled off.

Turn the cabinet on its side and remove the four chassis-securing bolts and washers. Unclear the speaker cable. The chassis is then free to the extent of the speaker cable.

The speaker (secured by six bolts) can

be removed if required, or, alternatively, the leads to the speaker panel unsoldered. For the reverse process the blue lead is connected to the lowest tag, the black lead to the one above it, and the red lead to the second tag from the top.

Special Notes.—The receiver has six pilot lights, all rated at 6 volts .3 amp.

The mains voltage adjustment device located at the rear of the chassis takes the form of three sockets, marked with respect to the voltageappings, and a connector that contains a fuse. If the fuse should blow, then this may be replaced by unscrewing the two metal connectors and feeding one-amp. fuse wire through the small hole provided.

A pair of sockets at the rear of the chassis enable a pick-up to be connected. Either a crystal or high impedance pick-up should be used.

A similar pair of sockets enable an

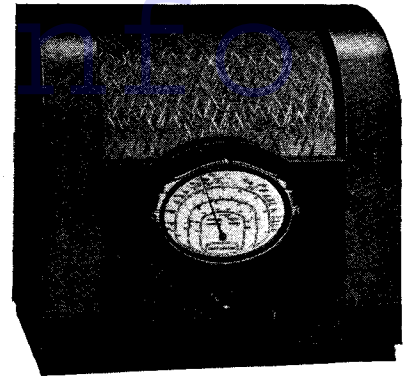

A full-vision scale illuminated in sections according to the setting of the wave change switch is a feature of the Decca 99.

RESISTANCES

R.	Purpose.	Ohms.
1	V1 A.V.C. feed	.5 meg.
2	V1 bias	200
3	V2 screen decoupling	15,000
4	V2 A.V.C. feed	.5 meg.
5	A.V.C. decoupling	.25 meg.
6	V2 bias	200
7	Osc. modifier	40
8	Osc. modifier	150
9	Osc. grid leak	50,000
10	P.U. shunt	50,000
11	V3 bias	200
12	A.V.C. diode load (part)	.3 meg.
13	A.V.C. diode load (part)	.5 meg.
14	L.F. coupling (on P.U.)	5,000
15	H.F. stopper	70,000
16	Tone control	.5 meg.
17	Diode load	.3 meg.
18	Volume control	.5 meg.
19	V5 stabiliser	150
20	V5 bias	100
21	Delay bias	150
22	A.V.C. feed	.3 meg.
23	Osc. anode feed	3,000
24	V2 stabiliser	50

CONDENSERS

C.	Purpose.	Mfd.
1	A.V.C. decoupling	.1
2	Grid blocking	.00005
3	V1 screen decoupling	.5
4	V1 bias decoupling	.1
5	M.W. fixed pad	.0003
6	V2 grid blocking	.0002
7	V2 screen decoupling	.1
8	V2 A.V.C. decoupling	.1
9	V2 bias decoupling	.1
10	Osc. grid	.0002
11	V3 decoupling	.06
12	V3 bias decoupling	.1
13	H.F. by-pass	.0001
14	L.F. coupling	.02
15	V5 compensator	.006
16	Tone control	.02
17	V5 bias decoupling	50
18	H.T. smoothing	16
19	V3 A.V.C. decoupling	.002
20	A.V.C. decoupling	.02
21	A.V.C. diode feed	.0001
22	H.T. smoothing	8
23	P.U. shunt	.006
24	S.W. 2 pad	.002
25	S.W. 1 pad	.005
26	S.W. 2 fixed trimmer	.002
27	M.W. fixed trimmer	.00025
28	L.W. fixed trimmer	.00005
29	Osc. anode feed	.0001
30	H.F. by-pass	.006
31	H.F. by-pass	.0001

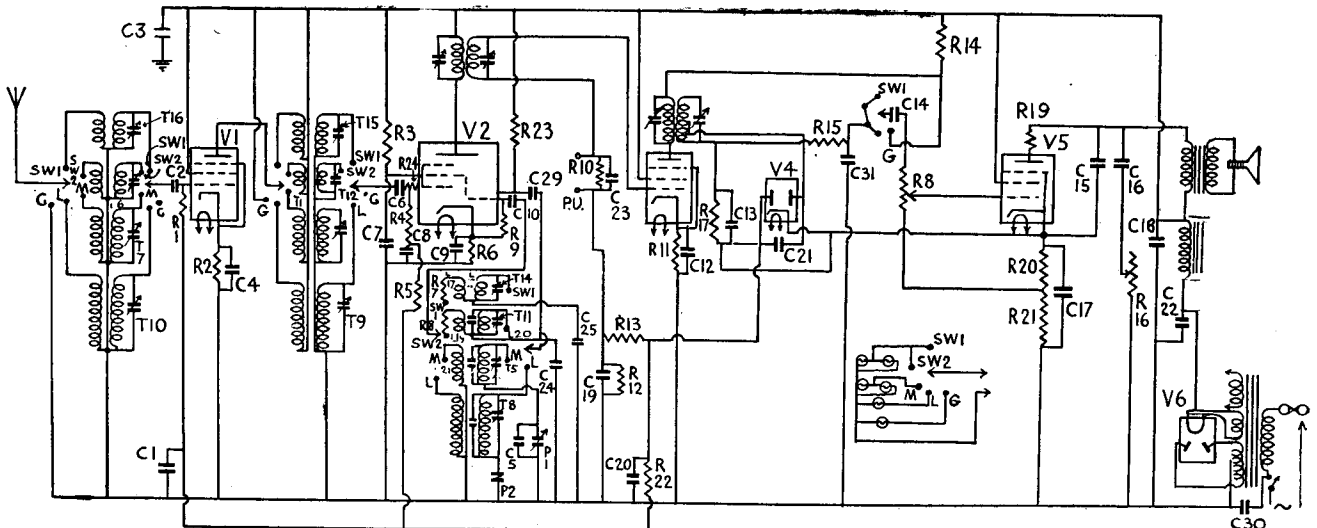

Reception on four wavebands is provided by the Decca 99 A.C. superhet. From the circuit it will be noticed that an H.F. pentode is employed as a pre-H.F. amplifier. A double diode is employed for second detection and A.V.C.

external speaker to be connected. This should be of the permanent magnet type with a matching transformer having an impedance of 9,000 ohms.

When the receiver is being used for gramophone reproduction, V3, the I.F. amplifying valve, is used as an L.F. amplifier. The pick-up input is injected into the grid circuit and by means of switching arrangements the output of V3 is fed to the grid of the pentode output valve.

Circuit Alignment Notes

I.F. Circuits.—Connect an output meter across the primary of the speaker transformer, and a service oscillator between the top grid and cap of V2 and chassis. Switch the receiver to the medium waveband and short circuit the oscillator section of the gang condenser.

Turn the volume control to the maximum position.

Tune the service oscillator to 456 kcs. and adjust T3 and T4 and then T1 and T2 for maximum, reducing the input from the oscillator as the circuits come into line to render the A.V.C. inoperative. The I.F. trimmers are sealed by red paper strips, which must be removed before alignment.

Signal Circuits.—Remove the short circuit from the oscillator section of the gang. Leave the output meter connected as before, but feed the oscillator to the aerial and earth terminals, via either a dummy aerial or fixed condenser. Only feed sufficient input from the oscillator to obtain definite peaks in the output meter so as to keep the A.V.C. inoperative.

Medium Waves.—Tune the set and oscillator to 200 metres (1,500 kcs.) and adjust first T5 and then T6 and T7 for maximum.

Tune the set and oscillator to 550 metres (545 kcs.) and adjust P1 for maximum, simultaneously rocking the gang to ensure optimum results.

Repeat both the above operations until no further improvement is noticed.

Long Waves.—Tune the set and oscillator to 1,000 metres (300 kcs.) and adjust first T8 and then T9 and T10 for maximum.

Tune the set and oscillator to 2,000 metres (150 kcs.) and adjust P2 for maximum, simultaneously rocking the gang to ensure optimum results.

Repeat both the above operations until no further improvement is noticed.

Short Waves.—Tune set and oscillator to 35 metres (8,571 kcs.) and adjust first T11 and then T12 and T13, and then finally retrim T11 for maximum response.

The padding is fixed, but check at 40 and 80 metres.

Tune the set and oscillator to 13 metres (23,077 kcs.) and adjust first T14 and then T15 and T16, finally retrim T14 for maximum response.

The padding is fixed, but check calibration at various wavelengths within the range covered.

Two condensers in the 99 are made by A. H. Hunt, Ltd. For replacements, the unit containing C18 and C22, list 3,475, is at 8s. 6d. C17 unit 3,351 is 1s. 10d.

Decca 99 on Test

MODEL 99.—Standard model for operation on A.C., 195-225 volts, 50-60 cycles. Price, 13½ gns.

DESCRIPTION.—Four-wave, six-valve, including rectifier, table model superhet.

FEATURES.—Full-vision scale illuminated in sections by wave switch. Concentric tuning and volume controls. Combined tone and master switch. Elliptical cone high-fidelity speaker. Pick-up and speaker sockets. Fuse in voltage adjuster.

LOADING.—75 watts.

Selectivity and Sensitivity

SHORT WAVES (12.5-35 and 35-90 metres).—Very good gain and easy handling. No drift. Adequate selectivity.

MEDIUM WAVES (200-550 metres).—Very good selectivity with well-maintained gain. Local stations spread on adjacent channels only.

LONG WAVES (800-2,000 metres).—Good gain and selectivity. All main stations received. Slight interference on Deutschlandsender. Good background.

Acoustic Output

Ample volume for ordinary room with very good balance and pleasing tone. Crisp attack with flat response and no noticeable colouration on speech.

Superhet Whistles

SUPERHET whistles are generally caused by one or two powerful local stations. These "force" their way through to the frequency changer and heterodyne with other stations within a range of twice the intermediate frequency. (An oscillator will beat with frequencies both higher and lower than its own frequency.)

The remedy is to increase preselection. If ganging cannot be improved a wavetrap connected in series with the set and tuned to the local station can be tried.

QUICK TESTS

Quick tests are available on this receiver on the leads to the speaker panel. Voltages measured between these and the chassis should be:—

- Red lead, 194 volts, smoothed H.T.
- Black lead, 172 volts, smoothed H.T.
- Blue lead, 319 volts, unsmoothed H.T.

VALVE READINGS

No signal. Volume maximum. M.W. band. 200 volts A.C. mains. 1,000 ohms/volt meter.

V.	Type.	Electrode.	Volts.	Ma.
1	Mullard VP4B (7 met.)	Anode ..	194	7.7
		Screen ..	194	3
2	Mullard TH4A (7 met.)	Anode ..	194	2.8
		Screen ..	90	5.9
		Osc.anode ..	80	3.3
3	Mullard VP4B (7 met.)	Anode ..	142	8.8
		Screen ..	194	3.1
4	Mullard 2D4A (5 met.)	Diodes only.	—	—
5	Mazda AC4/PEN (7)	Anode ..	170	34
		Screen ..	194	7.9
6	Mullard 1W4/350 (4)	Filament	319	—

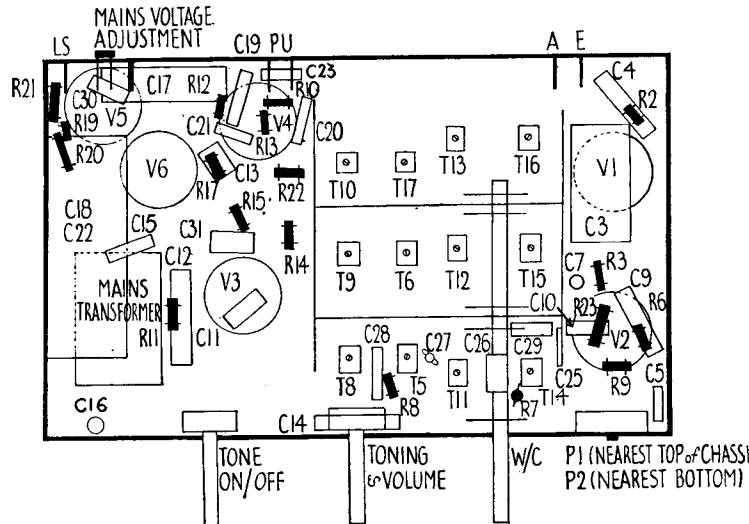
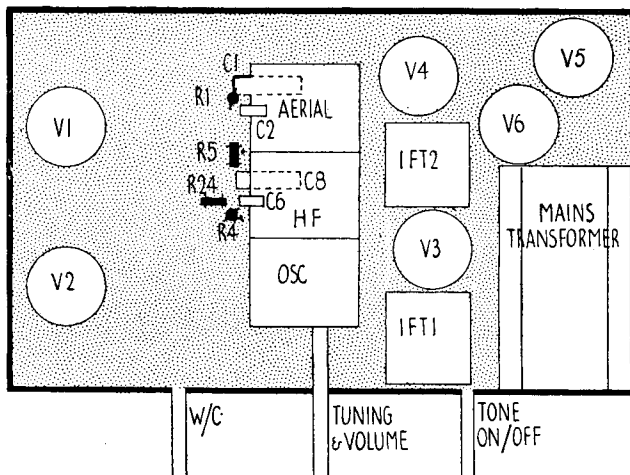

The simple layout of the upper side of the chassis of the Decca 99 is shown by the drawing on the left. The layout of the components underneath is shown on the right. If necessary, these can be reached by taking out the false bottom of the cabinet.

For more information remember

www.savoy-hill.co.uk