

For more information remember www.savoy-hill.co.uk

PETO-SCOTT BP41

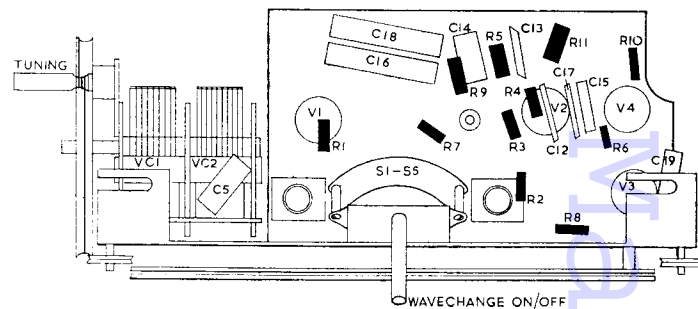

Four-valve two-waveband battery-operated super-het. Uses Ever Ready All-dry battery type 4 for LT and two 45 V Batrymax in series for HT90 V. Housed in leatherette-covered cabinet fitted with carrying handle. Manufactured by Peto-Scott Electrical Instruments Ltd., Addlestone Road, Weybridge, Surrey.

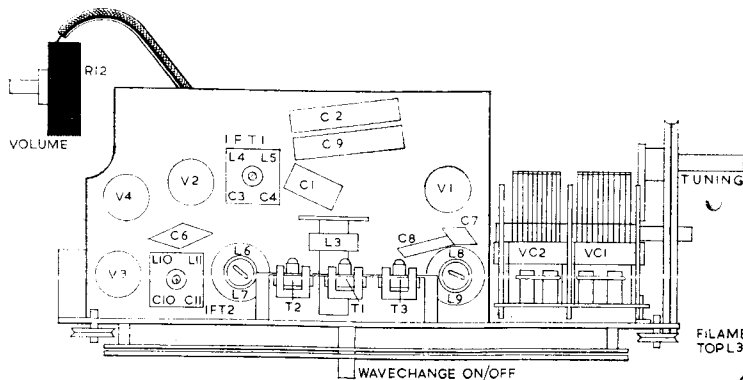
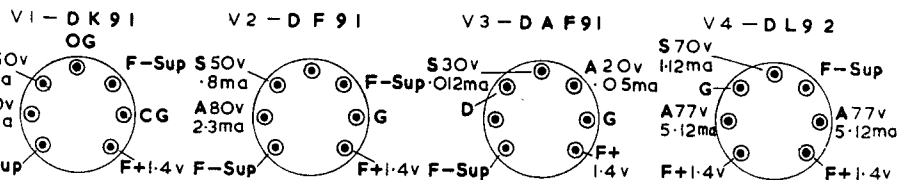
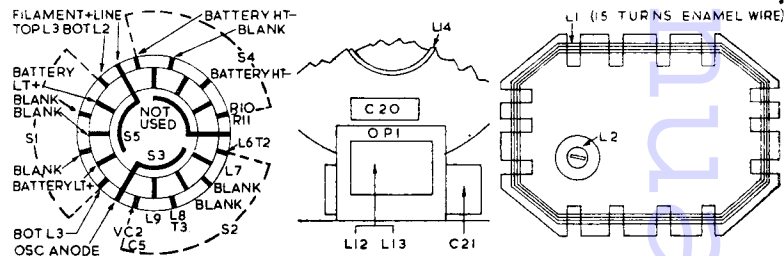

Circuit description and alignment instructions are given overleaf. Diagrams and components tables are grouped on this page for quick reference.

RESISTORS

R	Ohms	Watts
6	10 M	1/8 W
7	4.7 M	1/8 W
8	1 M	1/8 W
9	10 K	1/8 W
10	3.3 M	1/8 W
11	820	1/8 W
12	1 M	Potmeter

R	Ohms	Watts
6	10 M	1/8 W
7	4.7 M	1/8 W
8	1 M	1/8 W
9	10 K	1/8 W
10	3.3 M	1/8 W
11	820	1/8 W
12	1 M	Potmeter

CAPACITORS

C	Mfds	Type
1	47 pf	Silver Mica
2	.1	Tubular 350 v
3	100 pf	Silver Mica
4	100 pf	"
5	100 pf	"
6	680 pf	"
7	47 pf	"
8	180 pf	"
9	.1	Tubular 350 v
10	100 pf	Silver Mica
11	100 pf	"
12	100 pf	"
13	100 pf	"
14	.05	Tubular 250 v
15	.002	Mica
16	.1	Tubular 350 v
17	100 pf	Silver Mica
18	.1	Tubular 350 v
19	.05	Tubular 250 v
20	.005	350 v
21	8	Electrolytic 150 v

INDUCTORS

L	Ohms
1	.7
2	1
3	20.5
4	13
5	13
6	1.1
7	1.75
8	5
9	3.5
10	13
11	13
12	600
13	2
14	2.5

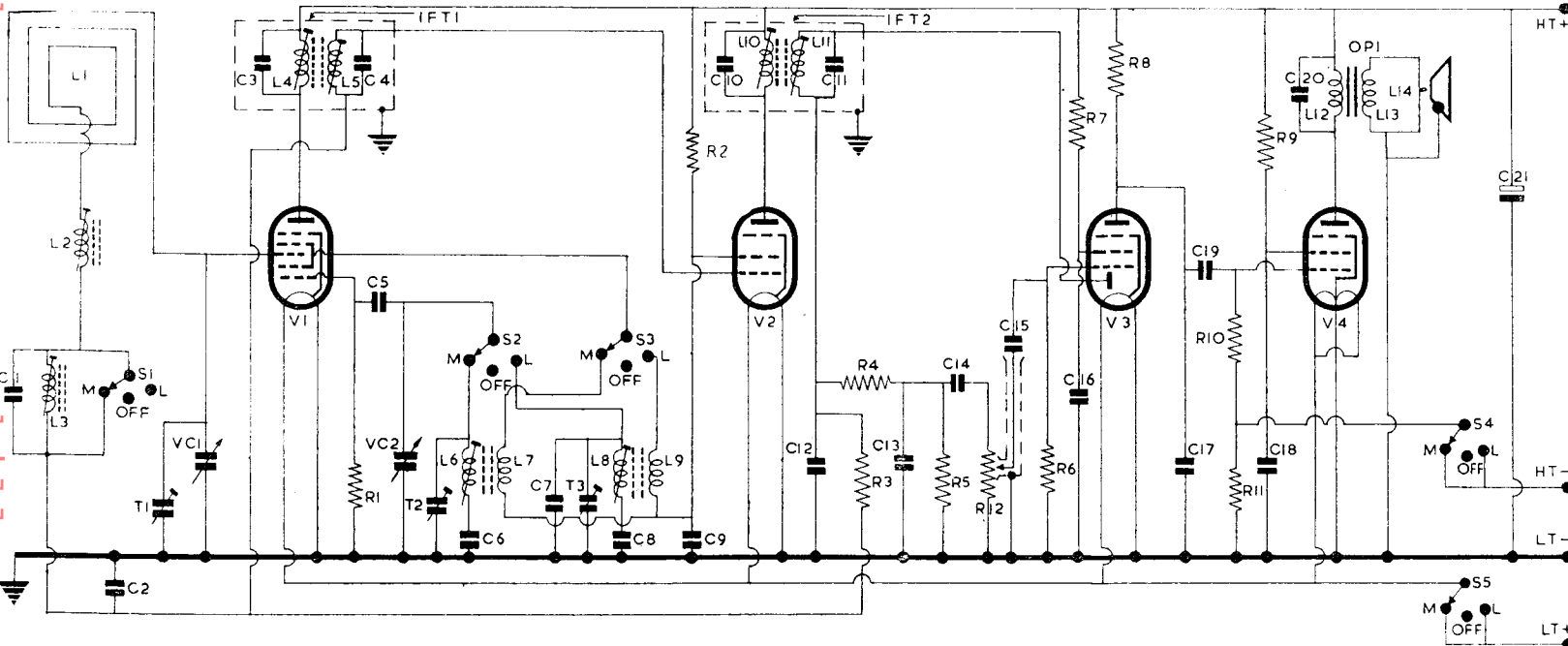

PETO-SCOTT BP41—Contd.

Circuit diagram, chassis diagrams and components tables are grouped together for quick reference on the preceding page.

CIRCUIT consists of a pentagrid frequency changer V1 feeding into RF pentode IF amplifier V2. A single-diode pentode V3 is used for signal rectification, automatic volume control and as an AF amplifier. The pentode output valve V4 drives a five-inch permanent-magnet loudspeaker. HT and LT are provided by all-dry batteries.

Aerial circuit consists of a frame aerial L1 coupled direct to grid V1, together with MW and LW loading coils L2 and L3. On LW operation L1, L2 and L3 are in series across the tuning capacitor VC1. LW trimming is carried out by the adjustable iron-dust core of L3. On MW operation L3 is short circuited by S1, leaving L1, L2 across VC1. T1 is MW capacity trimmer. AVC is fed to grid V1, in series with tuned circuits, from R3 and decoupled by C2. L4, C3, the primary of IFT1, is in the anode circuit V1.

Oscillator is connected in a series fed, tuned grid circuit. S2 selects grid coils L6 (MW), L8 (LW) which are tuned by VC2 and coupled by C5 to oscillator grid V1. T2 (MW), T3 (LW) are trimmers, and C6 (MW) C8 (LW) are padding capacitors. Self bias for oscillator grid is developed from C5, R1. S3 selects anode reaction coils L7 (MW), L9 (LW). Oscillator HT is obtained from R2, screen resistor for V2. C9 is decoupling capacitor.

IF amplifier operates at 465 kc/s. Secondary L5, C4 of IFT1 feeds signal to grid V2, and RF pentode. AVC voltages from R3 are fed, through L5, to grid. Screen voltage is obtained from R2 and decoupled by capacitor C9. R2 also supplies oscillator anode voltage. L10, C10, the primary of IFT2, is in the anode circuit of V2.

Signal rectification is carried out by the diode portion of V3 diode-pentode. L11, C11, the secondary of IFT2, feeds the signal to diode anode. R5 is the diode load resistor and R4, C12 and C13 form an IF filter. C14 feeds signal to R12, the volume control.

Automatic volume control. AVC voltages, which are obtained from the signal diode, are fed by R3 to grids V1, V2. C2 is AVC line decoupling capacitor.

AF amplifier. C15 feeds rectified signal to grid of pentode section V3. Bias for grid is developed on C15, with R6 as grid leak resistor. Screen voltage is obtained from R7 and decoupled by C16. R8 is its anode load and C17 anode HF by-pass capacitor.

Output stage. C19 feeds signal from anode V3 to grid V4, the pentode output valve. R10 is its grid resistor, the earthy end of which is returned to chassis through R11, the auto bias resistor. Screen voltage is obtained from R9 and decoupled by C18. L12, the primary of OP1, the output matching transformer, is in the anode circuit. C20 is tone correction capacitor. L13, the secondary of OP1, feeds a low-impedance speech coil L14 of the loudspeaker.

Filaments of V1, V4 are connected in parallel and connected by S5 to the all-dry LT battery of 1.4 volts. S5 is the filament on/off switch and is ganged to S4, the HT switch, and also to S1-S3, the wavechange switches.

High tension is provided by two 45-volt Batrymax batteries type B104, connected in series. C21 provides HT battery decoupling.

Removal from cabinet. Remove knobs of controls and take out. Remove batteries. Unscrew volume control locking nut and withdraw control. Unscrew two woodscrews and remove upper HT supporting bar. Loosen the two clips holding screened lead from chassis to output transformer and withdraw lead from under clip. Unsolder the frame aerial leads—loosen clip holding them; and withdraw leads from under clip. Remove 2BA nuts at end of chassis. Remove chassis (volume control end first).

When replacing chassis, position it to show equal number of vertical lines at each end of scale. Ensure that the scale fits flush by pushing chassis upwards before tightening chassis nuts.

TRIMMING INSTRUCTIONS

Apply Signal as Below	Tune Receiver to	Trim in order stated for Max. Output
1) 465 kc/s to grid V1 via .01 Capacitor. *	550 metres	L11, L10, L5 L4
2) 1.5 mc/s via loop near to frame aerial	200 metres	T2, T1
3) 600 kc/s as above	500 metres	L6, L2
4) 300 kc/s as above	1000 metres	T3
5) 150 kc/s as above	2000 metres	L8
6) 214 kc/s as above	1400 metres	L3

* Connect signal generator output to fixed plates of VC1 and to chassis, across IMEG resistor.

Note—when adjusting T1, L2, L3 the back of receiver should be in position.

B.T.H. Senior RK Loudspeaker

THE new B.T.H. Senior RK permanent-magnet loudspeaker is designed for high-fidelity reproduction.

The special feature of this model is in the use of a cone having a large curvature. This is claimed to produce a much wider and more level frequency response with reduction in sub-harmonics.

Speech coil former is moulded from specially impregnated paper and does not rely on the coil to keep it in shape. Thus distortion of the coil former, and its consequent fouling of the air gap, is minimised. The diameter of the speech coil is 1½ in. and centering is by means of a three-point flexible spider, mounted at the rear of the cone.

The cone is suspended in the heavy steel chassis by an outer ring of acoustically dead material. This method of suspension, together with the very flexible centering spider, results in exceptionally good reproduction of large amplitude low frequencies. A large pot magnet, having a total flux density of 134,000 lines, is used.

The speaker will handle up to 10 watts peak input. It is soundly constructed throughout and is finished in black enamel. On test the frequency response was found to be reasonably level from approximately 30 to 12,000 c/s. The fundamental resonant frequency is 45 c/s.

Marketed by Edison Swan Electric Co., Ltd., the speaker is listed at £6 15s.

V.E.S.—Calling Traders

In our latest trade list, we were able to offer many interesting lines. YOU may still be in time for these if you write at once. Why not play safe and have your name on our regular mailing list?

Goods supplied from stock as follows:—

Goodmans 12" Speakers in Cabinets, each	£7	17	6
Goodmans Cabinets only for 12" Speakers, each	£3	3	0
Goodmans 8" Speakers fitted with O.P. Trans., each	£1	2	4
Goodmans 8" Speakers less O.P. Trans., each		16	8
5" Mains Energised Speakers with O.P. Trans., each	£1	1	0
Extension Speakers in Veneered Cabinets with fitted Volume Control, each	£1	7	0
Varley All-Dry Accumulators V.40, each (less P.T.)		10	7
Varley All-Dry Accumulators V.60, each (less P.T.)		13	8
Varley All-Dry Accumulators PV.40, each (less P.T.)		11	4
Varley All-Dry Accumulators 7/15, each (less P.T.)		14	2
Varley Motor Cycle Accumulators, each	£1	5	10
Pullin Test Sets Series 100, 10,000 ohms per volt, each	£7	17	6
Wood Tool Boxes, each		7	6
Filament Transformers to give 6.3 volts primary tapped at 150 volts, each		9	0
Wall Telephones self-energising type, each		18	0
Perlite Aerials by "Aerialite," per 50 ft. Box		2	2
50 ft. "EL-ES" Aerials by "Aerialite," each		1	6
H.F. Chokes in Aluminium Cans, per dozen		12	0
Black Crackle Cabinets 9" x 4" x 4", each		12	6
4 Gang .0005 Tuning Condensers, each		9	6
8 MFD x 16 MFD 450 volt Electrolytics, per dozen	£3	12	0
The new Varley Super Quality Torch with trouble-free switch, each (less P.T.)		9	6
Alarm Bells, Double Gong Type, each		17	6
Avo Valve Testers, each	£14	0	0
Atkins Three Wave Band Coil Packs, each	£1	7	8
Midget I.F. Transformers 465 kcs, per pair		14	0

We have tried to give you an idea of the hundreds of different lines carried in our present stock, all of which are listed in our up-to-date price lists.

Send for your copy to

V.E.S., 42-46, Windmill Hill, Ruislip, Middlesex



"What's all this
soot?"
"Come a yell,
"O!s handiwork,
I can tell,"
Cried EE "Well,
by jiminy!
He's flopped down
the chimney
And taken our
FLUXITE as well!"

For all **SOLDERING** work you need **FLUXITE**—the paste flux—with which even dirty metals are soldered and "finned." For the jointing of lead—without solder and the "running" of white metal bearings—without "tinning" the bearing. It is suitable for **ALL METALS**—excepting Aluminium—and can be used with safety on Electrical and other sensitive apparatus. **With FLUXITE, joints can be "wiped" successfully that are impossible by any other method.** Of **ALL IRONMONGERS**, in tins—10d., 1/6 & 3/-

Used for over 40 years in Government works and by leading Engineers and Manufacturers. "The FLUXITE GUN" puts Fluxite where you want it by a simple pressure. Price 1/6 or filled 2/6.

FLUXITE

SIMPLIFIES ALL SOLDERING

Write for Leaflets on Case-Hardening Steel and Tempering Tools with FLUXITE, also on "Wiped" joints. Price 1d. each. **FLUXITE LTD., (Dept. T.E.), Bermondsey St., London, S.E.1.**

FOR ALL TIME
STURDY
REWINDS
SATISFACTION

Send your rewinds to Sturdy. All makes Radio Mains Transformers, Field Coils, etc. First-class work with quick delivery and fully guaranteed.

STURDY ELECTRIC CO., LTD.
DIPTON Tel.: DIPTON 221 NEWCASTLE-ON-TYNE